

PLANING VESSELS

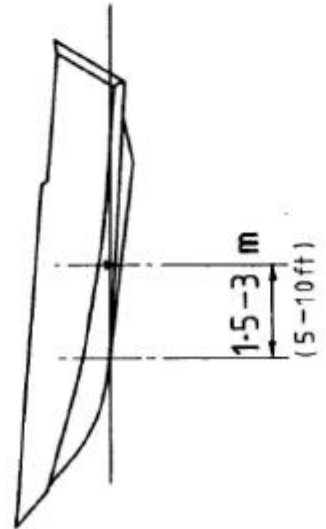

VERTICAL WITHIN 5°

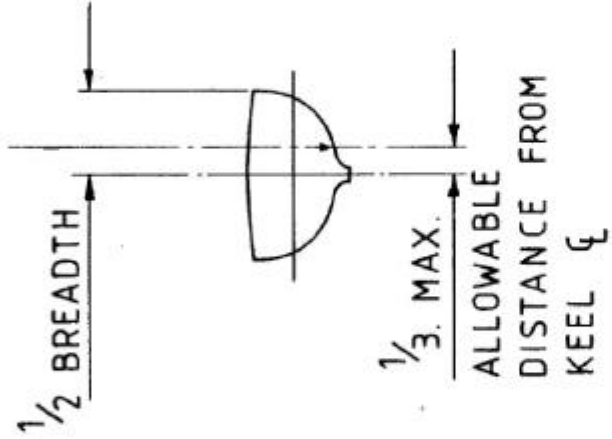

DISPLACEMENT VESSELS

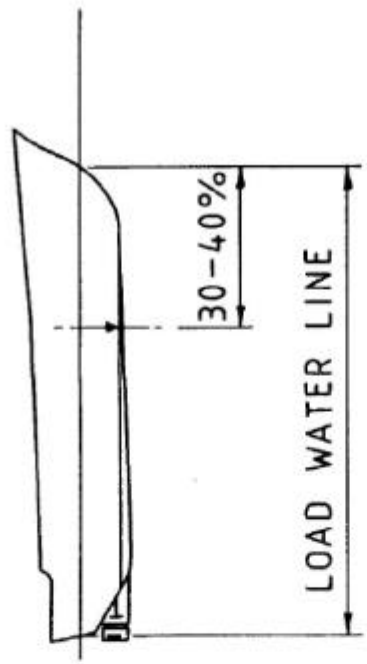

SCRAP VIEW SHOWING METHOD OF FINDING CLOSEST POINT TO KEEL FOR TRANSDUCER MOUNTING

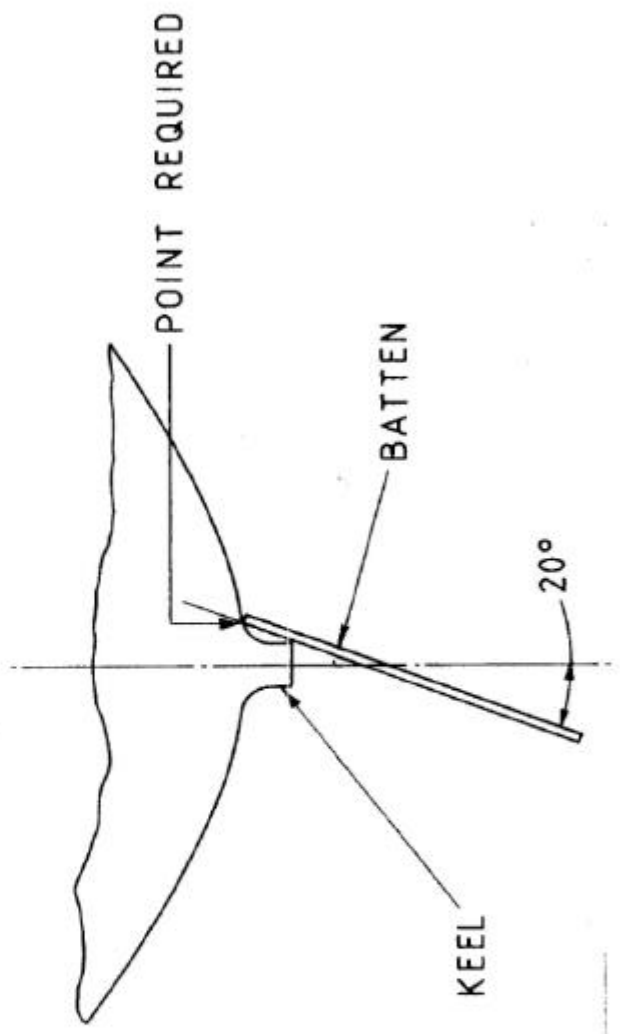

NOTES

1. TO STIFFEN THE SHELLED HULLS EITHER ADD WELDED WEBS AS REQUIRED OR AN INNER THICKENING PLATE.
  2. FLANGED BUSH (A) IS TO BE WELDED TO HULL AS SHOWN. CLEAN (A) & SURROUNDING AREA. PROTECT BORE OF (A) WITH SUITABLE GREASE.
  3. FAIR ITEM (A) TO HULL, WITH WELD BUILD UP OR EPOXY RESIN FILLER. PAINT (A) & SURROUNDING AREA TO MATCH HULL.
  4. USE A SEALING COMPOUND (PLASTIC GASKET) BETWEEN TUFNOL & METAL MATING SURFACES. & A THREAD LOCKING ADHESIVE ON SCREW THREADS.
  5. BLANKING CAP TO BE PLACED IN A HEAVY GAUGE POLYTHENE BAG & SECURED TO VALVE HOUSING.
  6. USE PADLOCK TO SECURE THE VALVE IN THE FULLY OPEN OR CLOSED POSITION.
- DIMENSIONS IN MM (INCHES)  
ITEMS A, B, C ETC. ARE SHOWN ON PAGES 9 & 10.

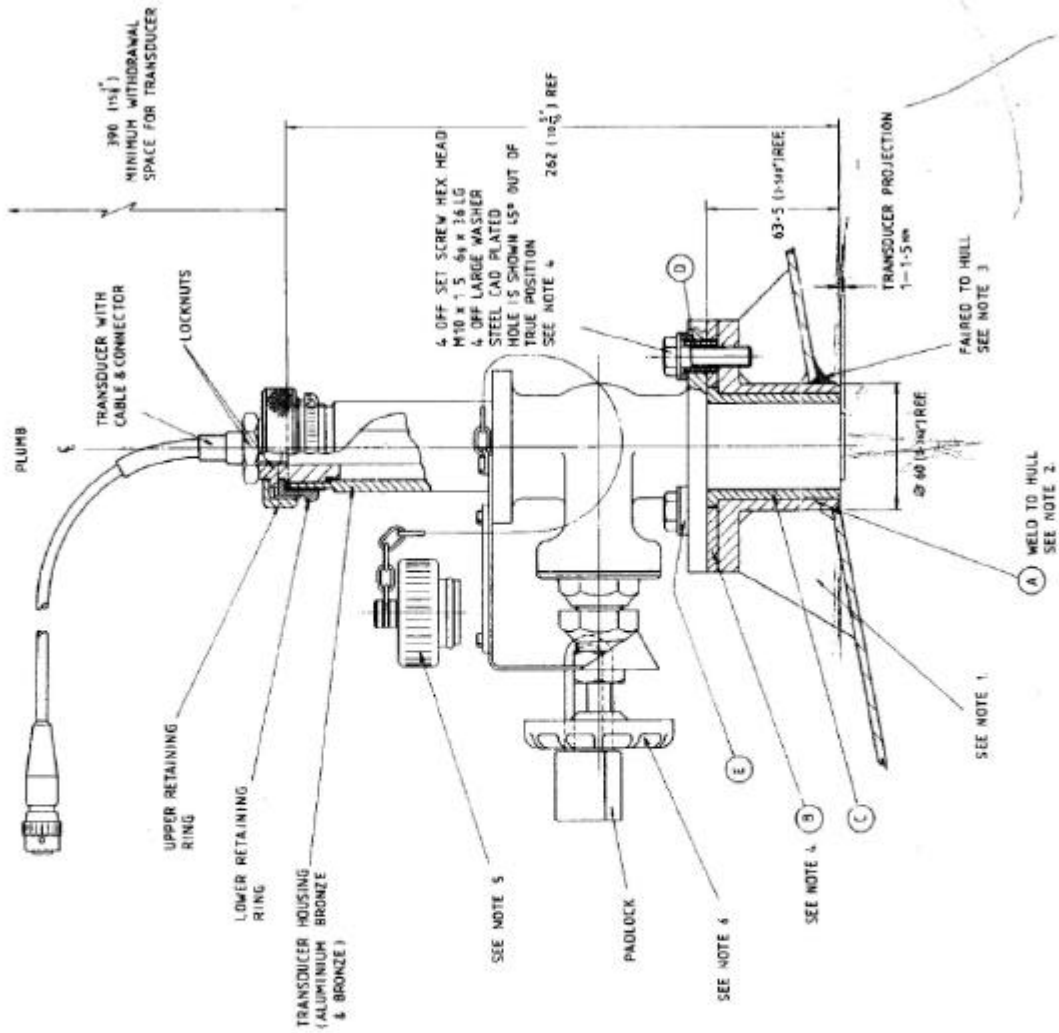

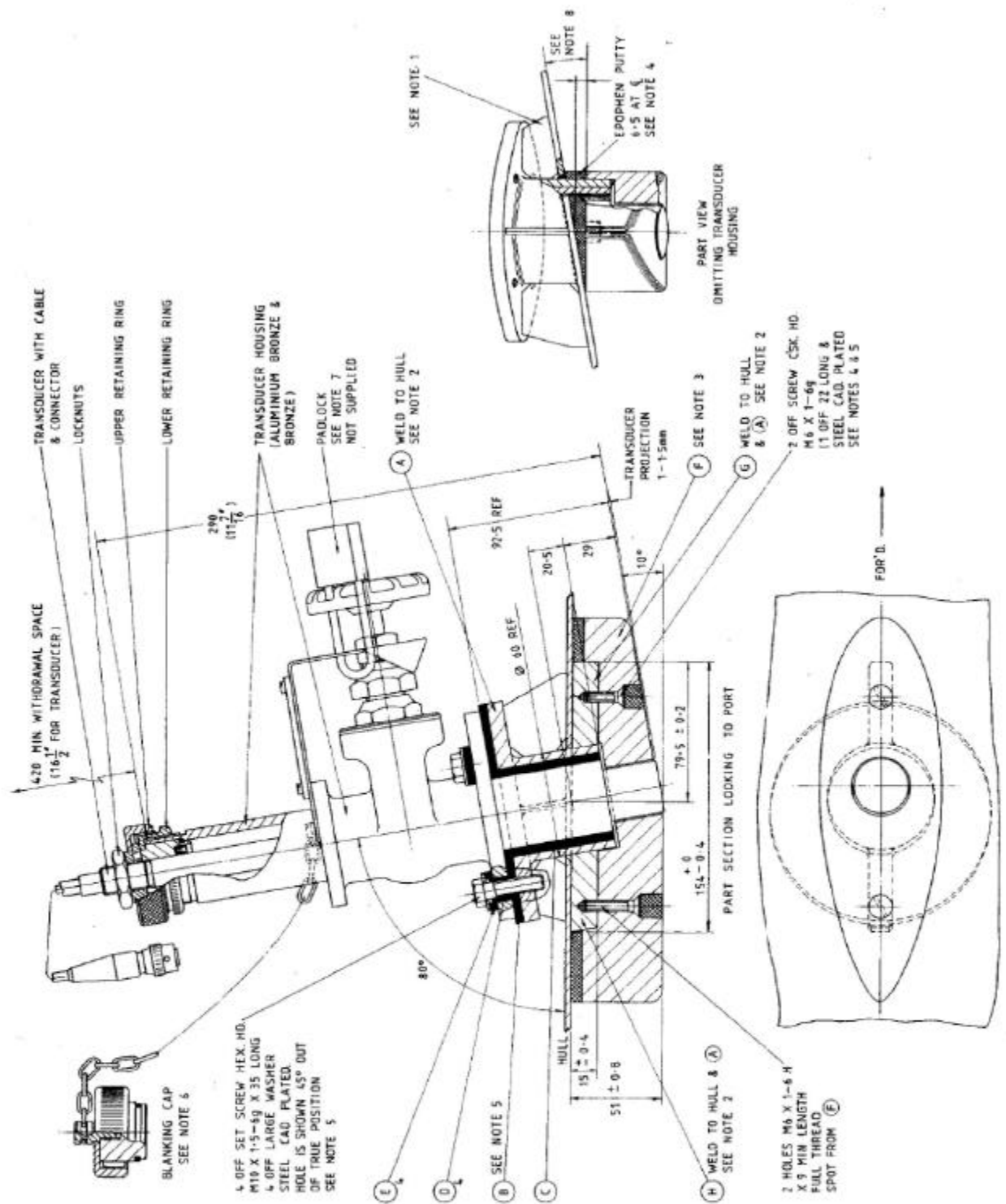

NOTES

1. TO STIFFEN THIN SHELL HULLS EITHER ADD WELDED WEBS AS REQD. OR AN INNER THICKENING PLATE.
  2. FLANGED BUSH (A) & ITEMS (G) & (H) ARE TO BE WELDED TO HULL AS SHOWN. CLEAN THESE ITEMS & THE SURROUNDING AREA & FINISH PAINT TO MATCH THE HULL. PROTECT BORE OF (A) WITH A SUITABLE GREASE.
  3. CHECK THAT THE FAIRING POD (F) SEATS ON ITEMS (G) & (H) & MAINTAINS THE 51 DIM.
  4. AFTER SPOTTING FROM THE FAIRING POD HOUSING (F) TO HULL USING EPOPHEN PUTTY AS A SEATING BLEND TO HULL AFTER CURING. FILL IN SCREW HEAD HOLES WITH A SUITABLE WOODEN OR CORK PLUG. GLUED IN POSITION. & FAIRED FLUSH. COAT WITH POLYURETHANE VARNISH.
  5. USE A SEALING COMPOUND (PLASTIC GASKET) BETWEEN TUFNOL & METAL MATING SURFACES, & A THREAD LOCKING ADHESIVE ON SCREW THREADS.
  6. BLANKING CAP IS TO BE PLACED IN A HEAVY GAUGE POLYTHENE BAG & SECURED TO THE TRANSDUCER HOUSING.
  7. USE PADLOCK TO SECURE THE VALVE IN THE FULLY OPEN OR CLOSED POSITION.
  8. FOR HULL DEAD RISE ANGLES IN EXCESS OF 10° THE INNER EDGE OF THE FAIRING POD (F) WOULD NEED TO BE MODIFIED. THIS DRAWING SHOWS A TYPICAL LAYOUT FOR USE WITH A METAL HULLED VESSEL WHERE THE ECHOSOUNDER IS BEING OPERATED AT SPEEDS ABOVE 15 KNOTS WHEN FITTED TO A WOODEN OR G.R.P. HULL.
  9. A SIMILAR LAYOUT IS REQUIRED EXCEPT THAT THE INSULATING TUFNOL SPACERS (COLOURED BLACK ON THE DRAWING) REQUIRED TO SEPARATE THE BRONZE VALVE FROM DISSIMILAR METALS ARE OMITTED.
- DIMENSIONS MUST BE ADJUSTED TO COMPENSATE FOR THE THICKNESS OF THE HULL CONCERNED AND THE OMISSION OF THE SPACERS SO THAT THE DIMENSION 92.5mm IS MAINTAINED. IF IN DOUBT CONTACT BROOKES & GATEHOUSE LTD. LYMPINGTON DIMENSIONS IN mm (INCHES) ITEMS A, B, C ETC ARE SHOWN ON PAGES 9 & 10.

**NOTES**

1. USE A SEALING COMPOUND (PLASTIC GASKET) BETWEEN GRP & TRANSDUCER HOUSING FLANGE, AND A THREAD LOCKING ADHESIVE ON SCREW THREADS.
  2. BLANKING CAP TO BE PLACED IN A HEAVY GAUGE POLYTHENE BAG AND SECURED TO VALVE HOUSING.
  3. USE PADLOCK TO SECURE THE VALVE IN THE FULLY OPEN OR CLOSED POSITION.
- ITEMS A, B, C ETC ARE SHOWN ON PAGES 9 & 10.

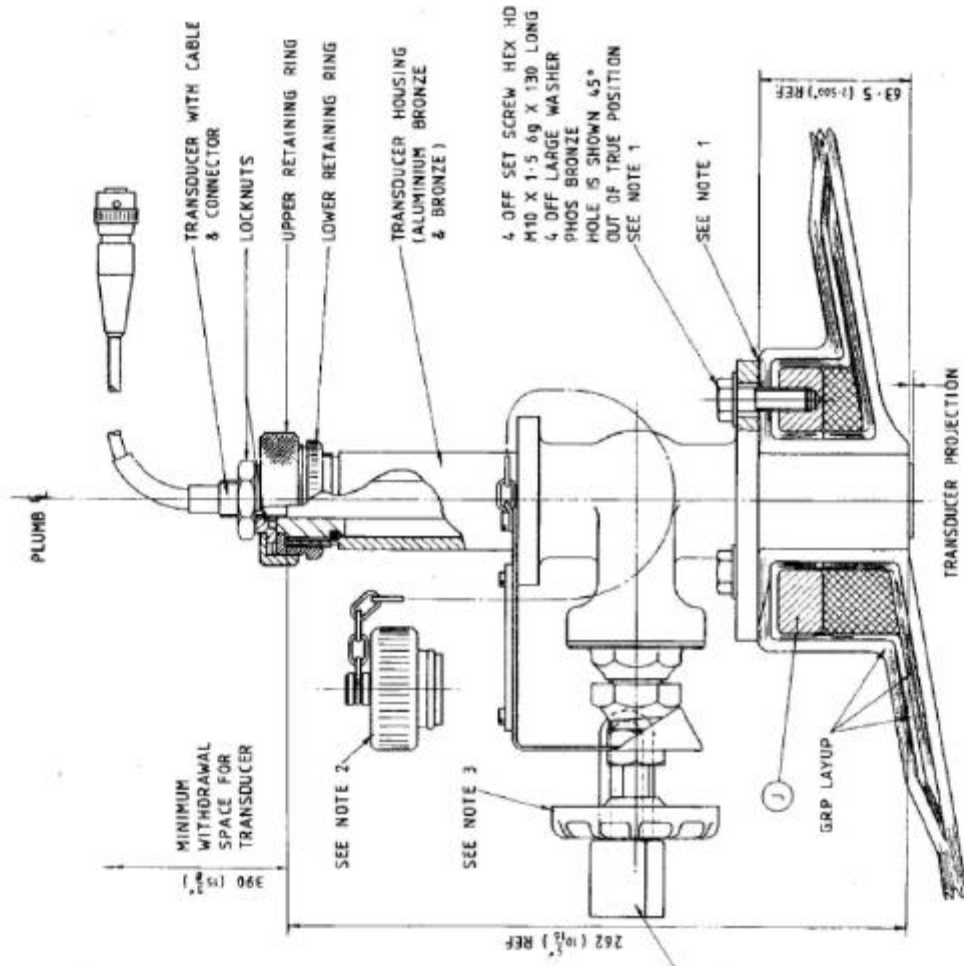

TYPICAL INSTALLATION IN GRP-HULLS

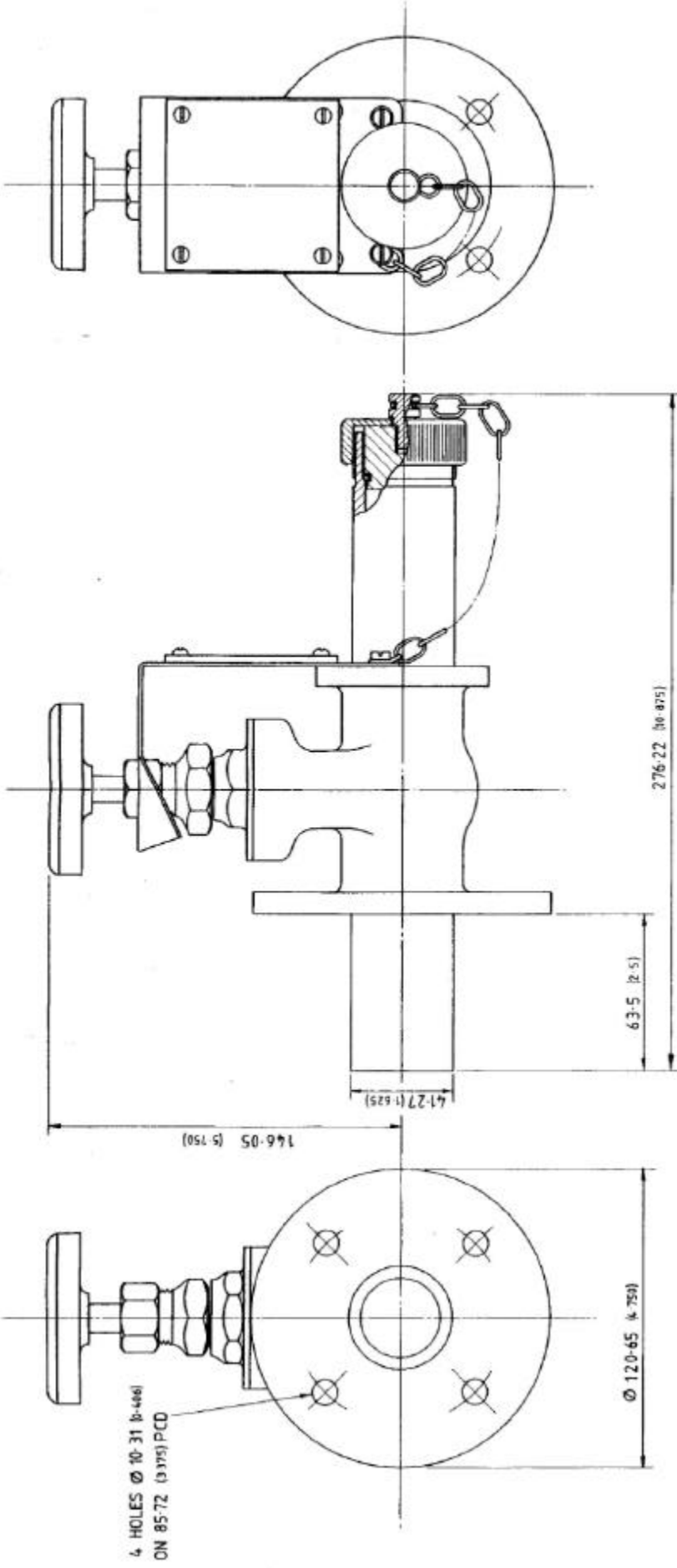

DIMENSIONS IN mm (INCHES)